

INSTALLATION MANUAL

Innolumis

INSTALLATIEHANDLEIDING
INSTRUCTIONS DE MONTAGE
MONTAGEANLEITUNG
ISTRUZIONI DI MONTAGGIO
INSTRUCCIONES DE MONTAJE

MINI
MAXI **Victoria**



CAUTION, RISK OF
ELECTRIC SHOCK



IEC EN60598	IP66	IK08	220-240VAC 50-60Hz					
-----------------------	-------------	-------------	-----------------------	--	--	--	--	--

MINI Victoria

 4,7kg	Cd x S 0.029m ²	
-----------	-------------------------------	--

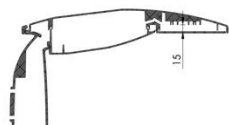
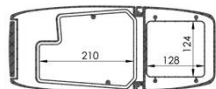
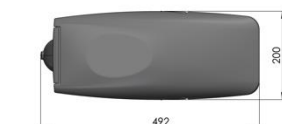

Victoria

 7,5kg	Cd x S 0.039m ²	
-----------	-------------------------------	--

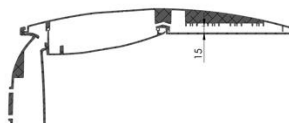
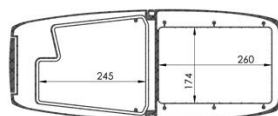
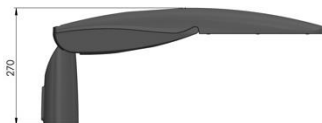

MAXI Victoria

 13,8kg	Cd x S 0.047m ²	
------------	-------------------------------	--

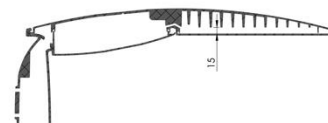
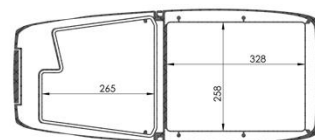

THE LIGHT SOURCE CONTAINED IN THIS LUMINAIRE SHALL ONLY BE REPLACED BY THE
MANUFACTURER OR HIS SERVICE AGENT OR A SIMILAR QUALIFIED PERSON.

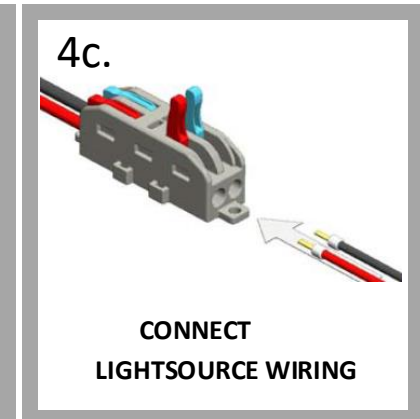
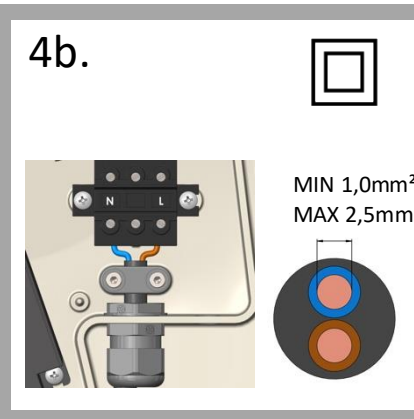
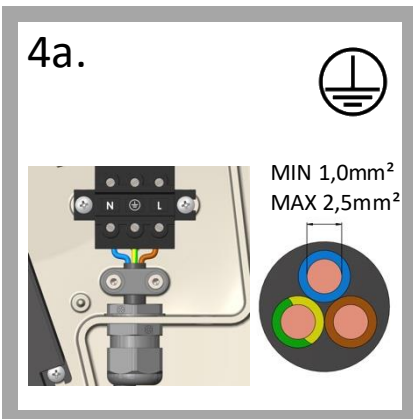
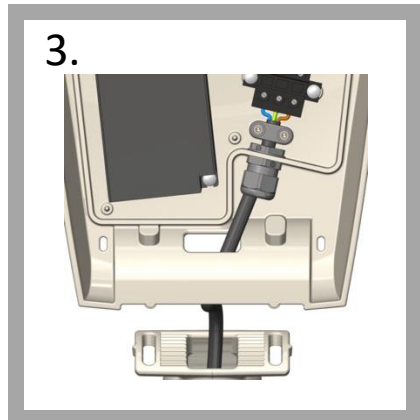
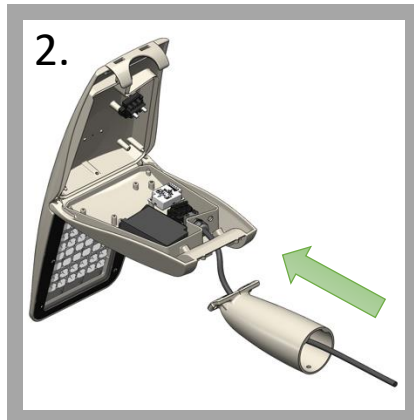
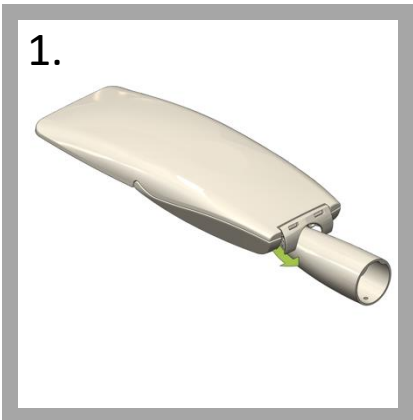
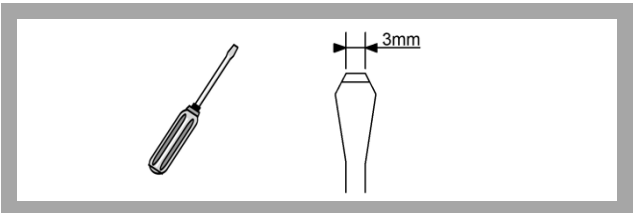
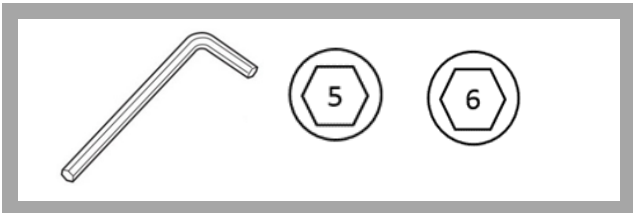

USE CORRECTLY RATED POWERCORD, ACCORDING TO LOCAL LEGISLATION
ALWAYS USE FERRULES WHEN CONNECTING THE POWERCORD TO THE LUMINAIRE
CHECK MARKINGS ON POWERENTRY CONNECTOR WHEN CONNECTING THE POWERCORD

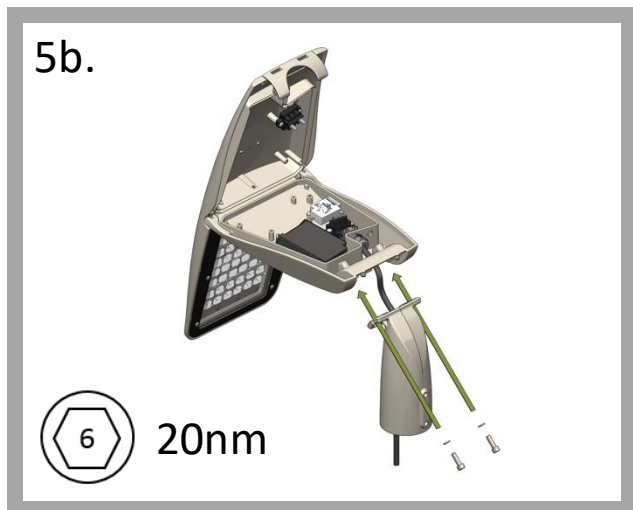
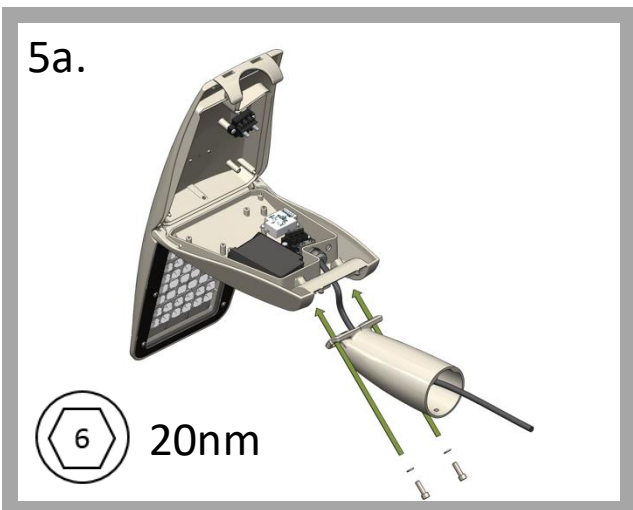

6a.

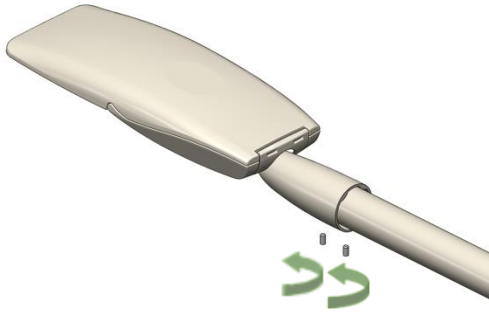

 20nm

6b.



 20nm

PLEASE MAKE SURE TO LUBRICATE ALL NUTS/BOLTS WITH AN APPROPRIATE GREASE OR LUBRICATION. SUGGESTION: KROON OIL CERAMIC GREASE.

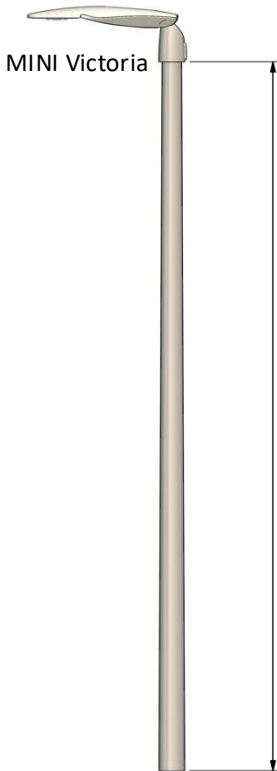

MINI Victoria

MAX 8 METER

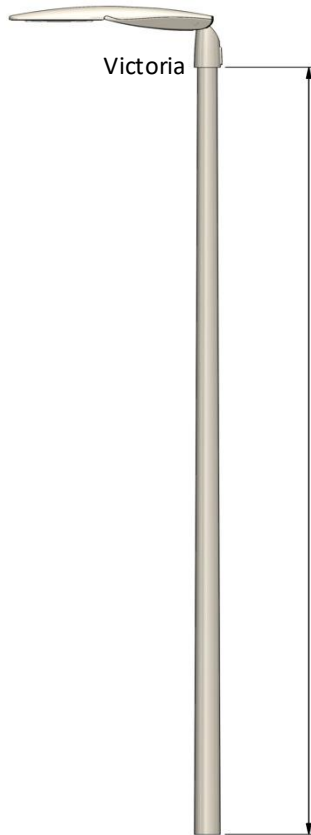

Victoria

MAX 12 METER

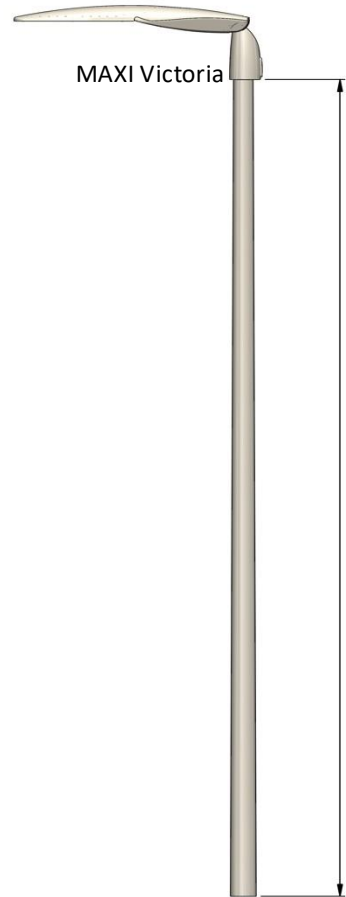

MAXI Victoria

MAX 16 METER

Innolumis Public Lighting B.V.

Ariane 4
 3824 MB Amersfoort
 the Netherlands
 T +31 (0)33 760 04 34
 F +31 (0)33 760 01 35
 E info@innolumis.com

Innolumis

www.innolumis.com