

# INSTALLATION MANUAL

# Innolumis

MINI  
MAXI **Victoria**

INSTALLATIEHANDLEIDING  
INSTRUCTIONS DE MONTAGE  
MONTAGEANLEITUNG  
ISTRUZIONI DI MONTAGGIO  
INSTRUCCIONES DE MONTAJE



CAUTION, RISK OF  
ELECTRIC SHOCK



<b>IEC</b> EN60598	IP66	IK08	220-240VAC 50-60Hz					
-----------------------	------	------	-----------------------	--	--	--	--	--

## MINI Victoria

 4,7kg	Cd x S 0.029m <sup>2</sup>	
-----------	-------------------------------	--

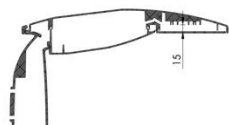
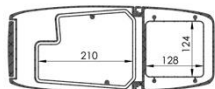

## Victoria

 7,5kg	Cd x S 0.039m <sup>2</sup>	
-----------	-------------------------------	--

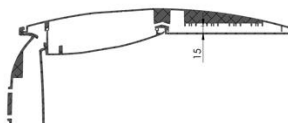
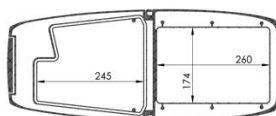
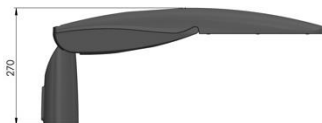

## MAXI Victoria

 13,8kg	Cd x S 0.047m <sup>2</sup>	
------------	-------------------------------	--

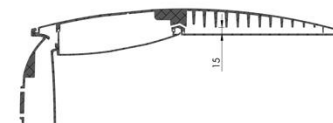
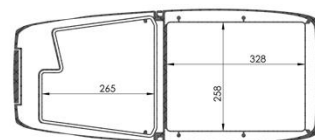

THE LIGHT SOURCE CONTAINED IN THIS LUMINAIRE SHALL ONLY BE REPLACED BY THE MANUFACTURER OR HIS SERVICE AGENT OR A SIMILAR QUALIFIED PERSON.

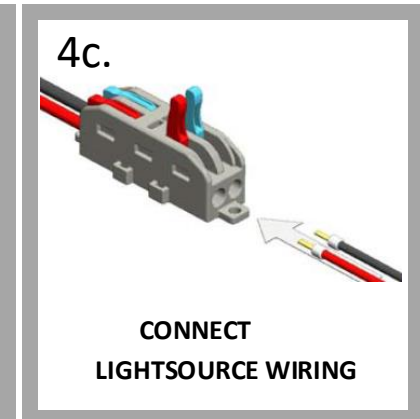
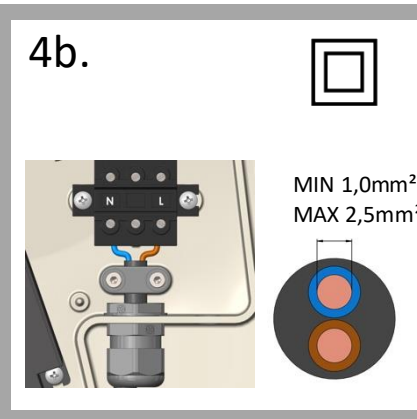
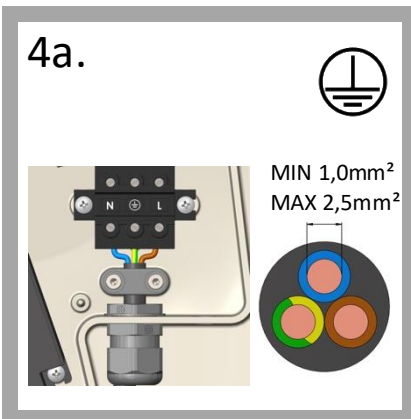
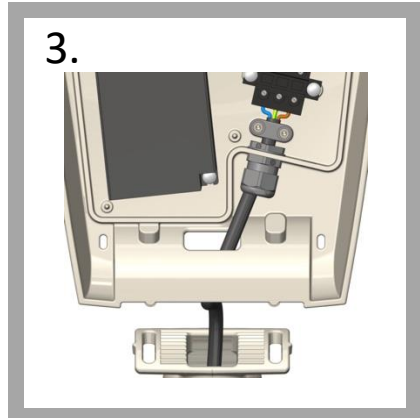
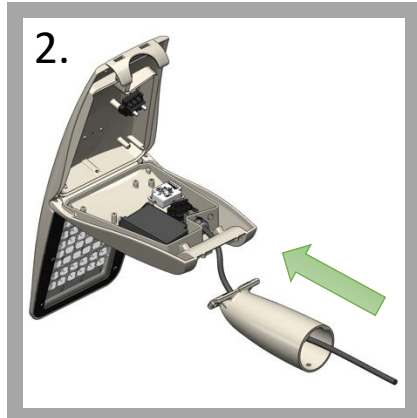
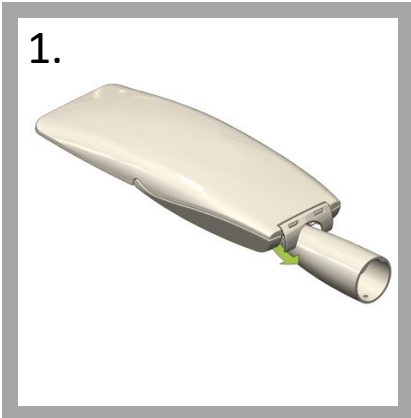
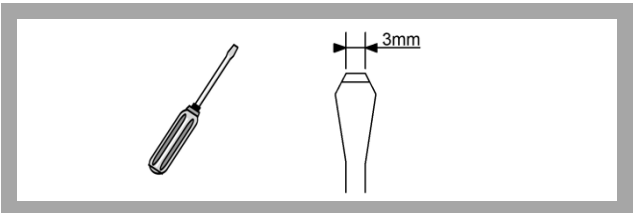
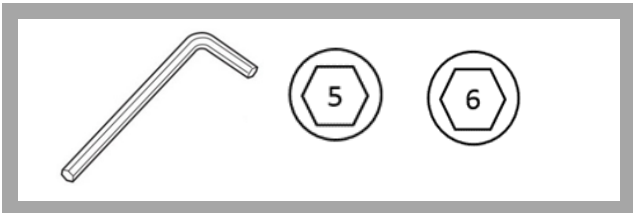

**USE CORRECTLY RATED POWERCORD, ACCORDING TO LOCAL LEGISLATION**  
**ALWAYS USE FERRULES WHEN CONNECTING THE POWERCORD TO THE LUMINAIRE**  
**CHECK MARKINGS ON POWERENTRY CONNECTOR WHEN CONNECTING THE POWERCORD**

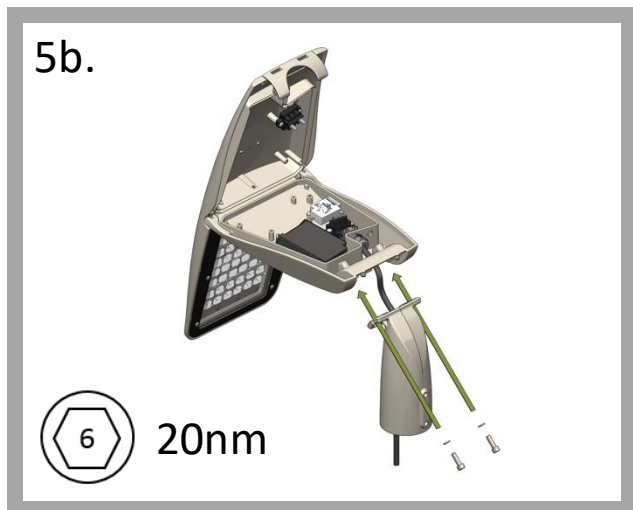
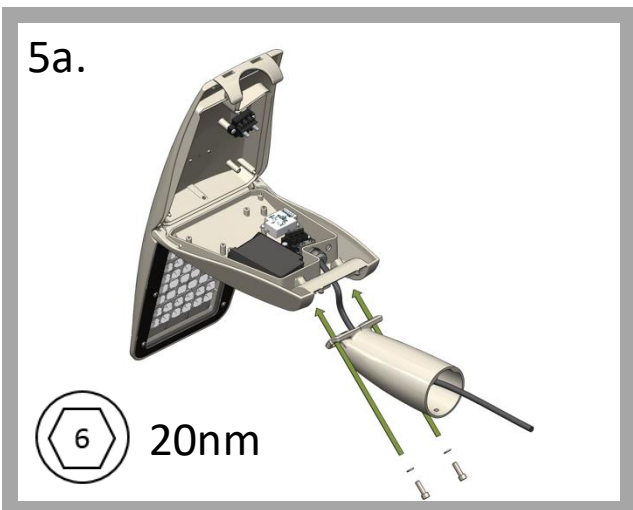

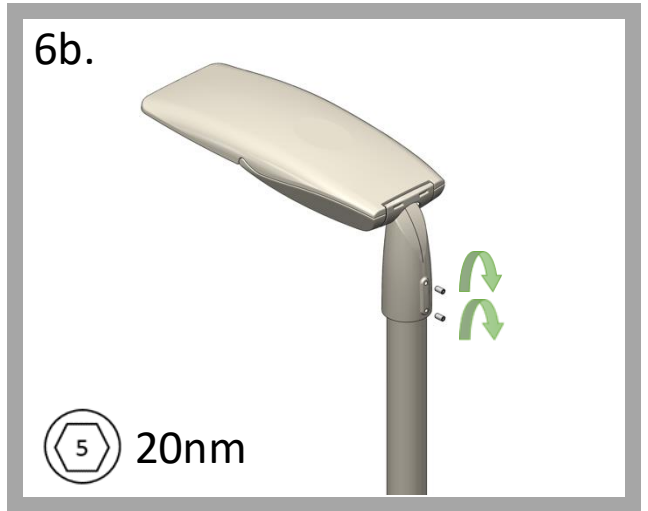
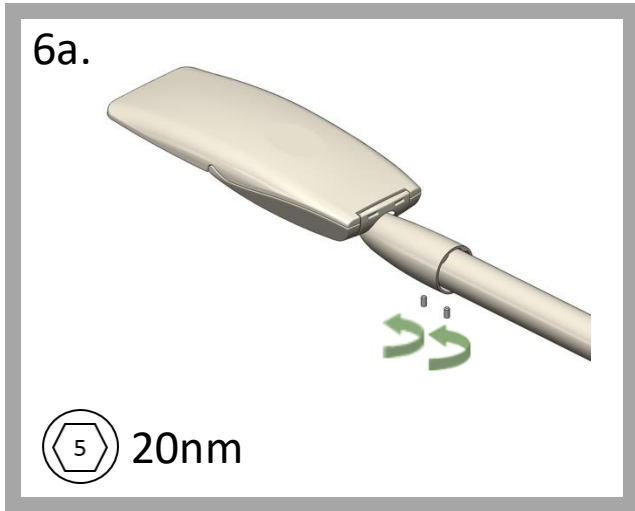

**PLEASE MAKE SURE TO LUBRICATE ALL NUTS/BOLTS WITH AN APPROPRIATE GREASE OR LUBRICATION. SUGGESTION: KROON OIL CERAMIC GREASE.**

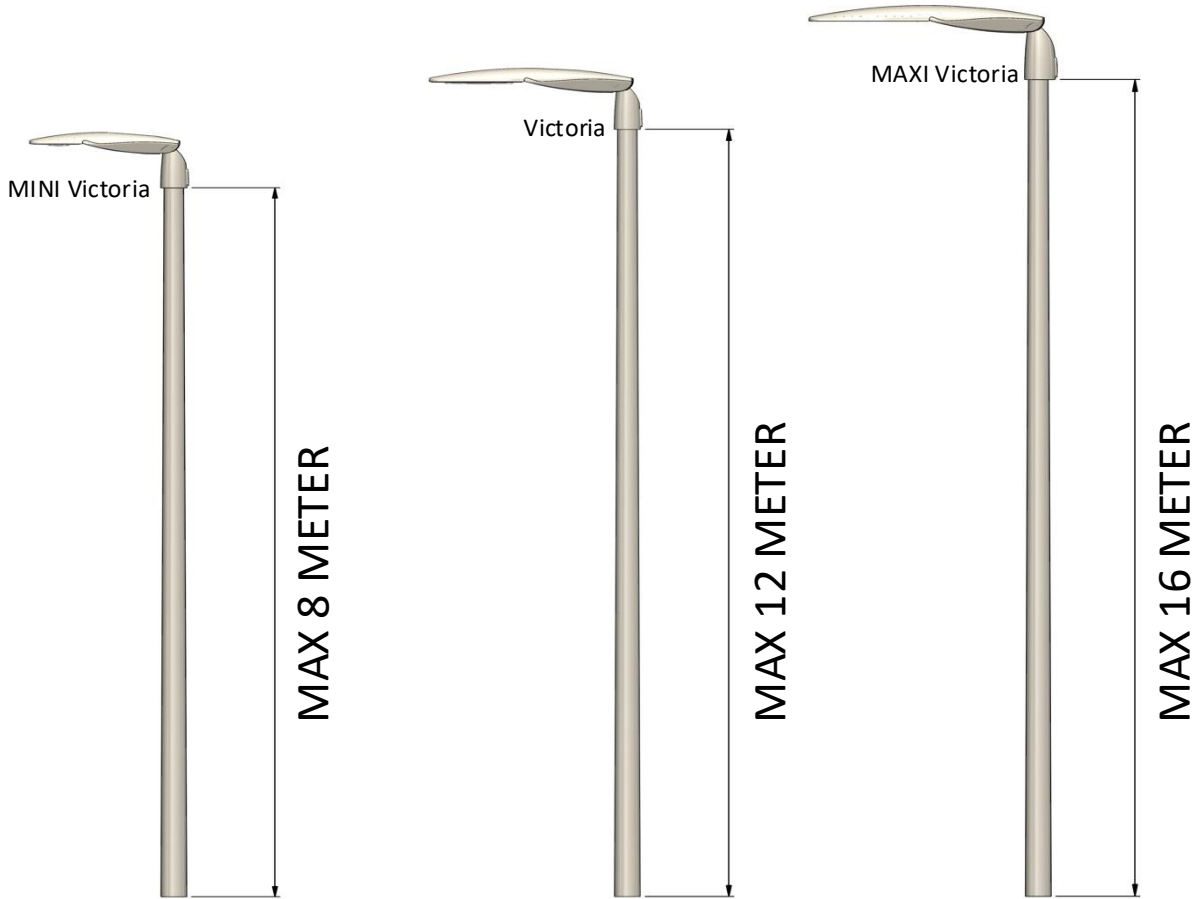

**Innolumis Public Lighting B.V.**

Ariane 4  
 3824 MB Amersfoort  
 the Netherlands  
 T +31 (0)33 760 04 34  
 F +31 (0)33 760 01 35  
 E info@innolumis.com

**Innolumis**

[www.innolumis.com](http://www.innolumis.com)